



CLARK EUROPE GMBH
 Neckarstrasse 37
 D-45478 Mülheim an der Ruhr/Germany
 Tel.: +49 208 377336-0
 Fax: +49 208 377336-36
 www.clarkmheu.com
 info-europe@clarkmheu.com

1. Characteristics						
1.1	Manufacturer				CLARK	
1.2	Model	denomination of model in production			C PT 16	
				1.150 x 540	980 x 670	
1.3	Capacity	Q	nominal capacity	Kg	1.600	
1.4	Load center	c	distance to load center	mm	600	500
1.5	Power	E =Elektric			E	
1.6	Control	T = Tiller / A = Pedestrian			T / P	
1.7	Service Brake	M (mechanic) I (hydraulic) E (electric)			E	
1.8	Parking Brake	(.) pedal (..) parking (...) tiller arm			(.) (..)	
2. Wheels						
2.1	Wheels type	plt = polyurethane g= rubber			plt	
2.2	Wheels		quantity (x =traction) front/rear	Nr.	2 + 1x /2	
			front wheels size	mm	250 / 100	
			rear wheels size	mm	85	
3. Dimensions						
3.1	Lifting	h2	lifting	mm	120	
3.2	Max. dimensions	L2	length overall including forks face	mm	530	
		B	width	mm	710	
3.3	Wheel base	Y	wheel base	mm	1.355	1.185
3.4	Wheel base	at wheels center front/rear		mm	550 / 360	500 / 490
3.5	Clearance	chassis		mm	55	
		cuttriggers		mm	25	
3.6	Turning radius	Wa	radius	mm	1.600	1.430
3.7	Stacking aisle	Ast3	with pallet (800x1.200 / 1.000x1.200)	mm	/	
4. Performances						
4.1	Speeds	traction with/without load		km/h	5.8 / 6	
		lifting with/without load		m/sec	0.04 / 0.05	
		lowering with/without load		m/sec	0.26 / 0.06	
4.2	Gradeability	nominal 30' with/without load		%	/	
4.3	Max. gradeability	for 5' with/without load		%	10 / 18	
4.4	acceleration time	from 0 to 10 m with/without load		sec	/	
5. Weight						
5.1	Total weight	battery included		Kg.	435	425
5.2	Axle loading	with load front/rear		Kg.	/	
		without load front/rear		Kg.	/	
6. Battery - Motors						
6.1	Battery	volatge		V	24	
		capacity		Ah	156	
		min. weight		Kg.	140	
6.2	Electrical	traction (S2 - 60')		KW	0.85	
		lifting (S3 - 20%)		KW	2	
6.3	Hydraulic pressure	max. pressure		bar	120	
6.4	Noise level	operators place		dB	< 70	

CLARK EUROPE GMBH has the right to change datas and informations without prior announcement. Informations and datas anre not binding.

POS.		C PT 16	
		1.150x540	980x670
Q	Kg.	1.600	
c	mm	600	500
l	mm	1.150	980
L	mm	1.695	1.525
x	mm	170	
x2	mm	170	
Y	mm	1.355	1.185
L2	mm	545	
L1	mm	1.930	1.730
m	mm	540	670
n	mm	180	
s	mm	60	
h2	mm	120	
a	mm	100	
Wa	mm	1.600	1.430
Ast3	mm	2.130	1.930

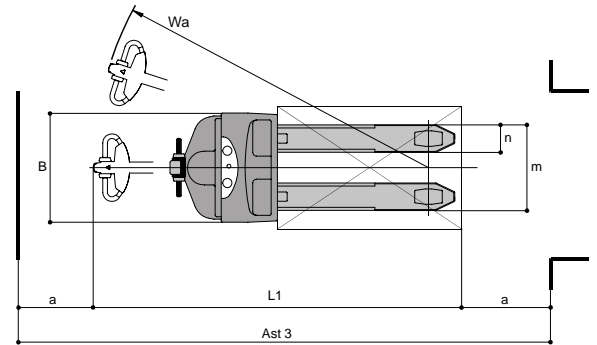
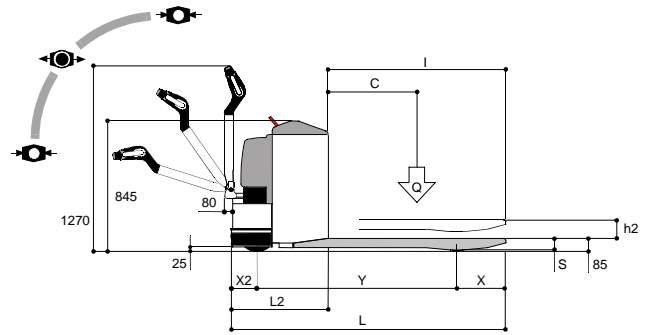

CLARK
THE FORKLIFT

C PT 16
Pedestrian-Power
Pallet-Truck